

FEATURES AND BENEFITS

1. The Series 365 is designed specifically for handling knotter rejects and sand cleaners where high abrasion resistance and bubble-tight shutoff is a necessity
2. Gate, seat cartridge & gate guides are 420 Stainless Steel, heat treated and hardened (RC60) to withstand the highly abrasive media
3. Back side of seat cartridge is machined to accept a Viton Elastomer L-Seal allowing for Class V shutoff when gate is in the fully closed position. This prevents media from leaking while valve is in closed position
4. Precision machined body castings prevent accumulation of solids and trash which would prohibit the valve from fully opening and or closing
5. Valve design allows for complete factory rebuild to like new condition at 50%-60% of the current list price
6. Gates are chrome plated to reduce friction and valve torque extending the life of the packing
7. Black liquor is byproduct of the kraft process and is found in both the knotter and sand cleaner services. Black liquor has an extremely low viscosity and is known in the paper industry for leaking. Our premium packing is impregnated with a proprietary blocking agent and designed to be highly durable. This packing is excellent for high cycle, abrasive applications
8. All NPV valves designed for recycle/ heavy trash applications are equipped with high-cycle, premium carbon packing
9. All NPV/DUCO valves are supplied with NPV high cycle pneumatic cylinder, limit switch brackets and stainless steel mechanical lockout. Locks in closed position only.
10. Valve is available in sizes 6", 8" 10"

NOTE: Valve must be installed in the horizontal position

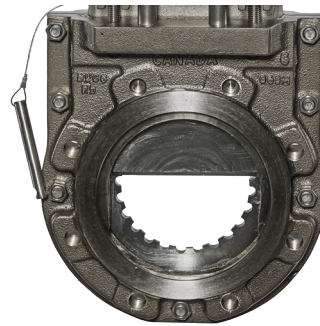
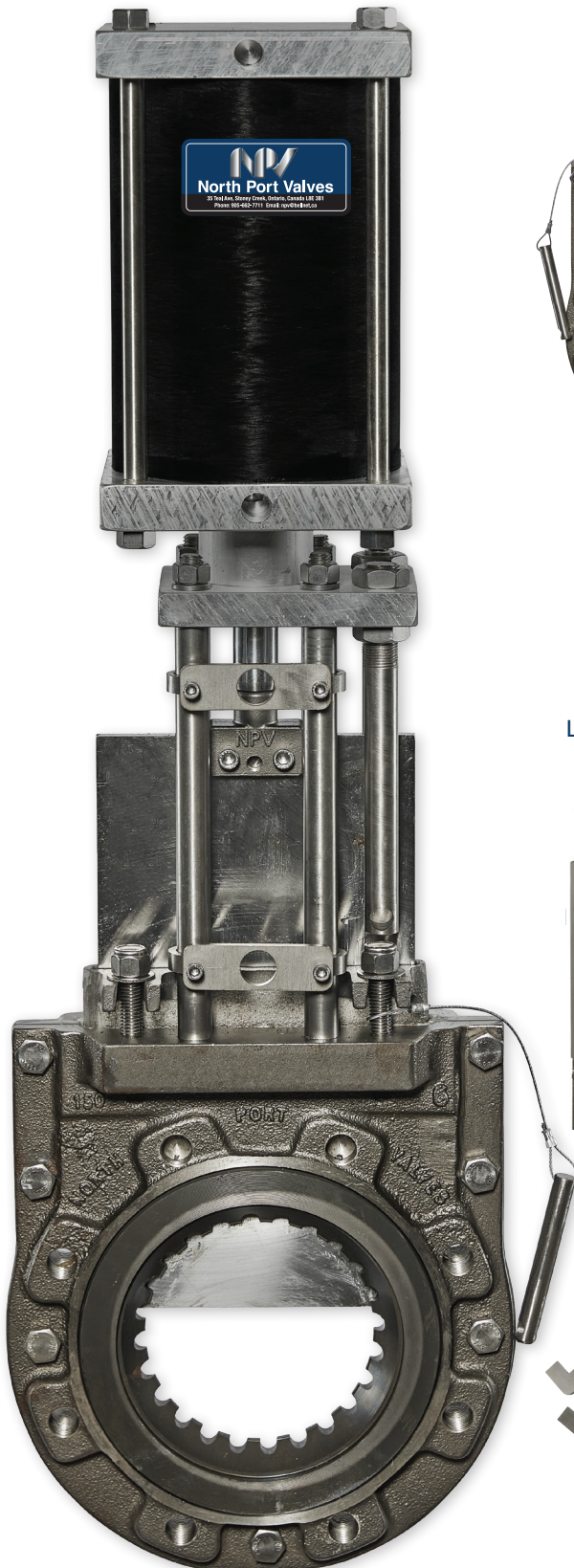

L Shape Seal on backside of cartridge



Safety guards available upon request



Factory replaceable - hardened gate, cartridge and guide

NPV KNOTTER REJECTS/SAND CLEANER VALVE SERIES 365

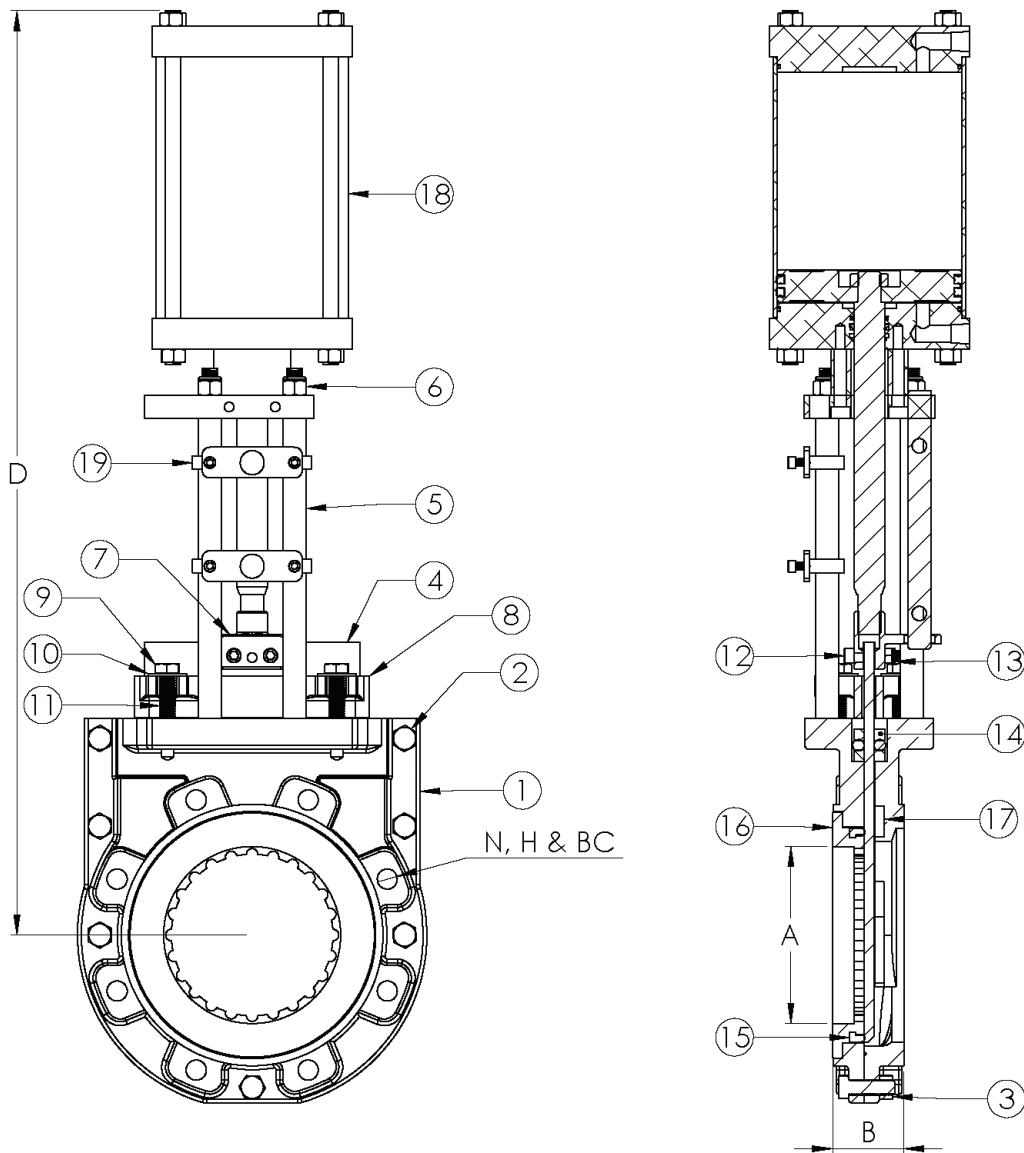

	6"	8"	10"
A	5 3/4"	7 5/8"	9 1/2"
B	2 1/4"	2 3/4"	2 3/4"
N(HOLES)	8	8	12
H(TAP)	3/4" - 10	3/4" - 10	7/8" - 9
BC	9 1/2"	11 3/4"	14 1/4"
D	29 3/4"	38 1/4"	46"

#	PART NAME	MATERIAL
1	BODY	CG8M (317 S.S.)
2	BODY BOLTS	18.8 S.S.
3	BODY NUTS	18.8 S.S.
4	HARDENED GATE	420 S.S.
5	STANCHION	303 S.S.
6	STANCHION NUT	18.8 S.S.
7	COUPLING	CG8M (317 S.S.)
8	GLAND	CG8M (317 S.S.)
9	GLAND NYLOCK NUT	18.8 S.S.
10	GLAND WASHER	18.8 S.S.
11	GLAND STUD	18.8 S.S.
12	COUPLING BOLT	18.8 S.S.
13	COUPLING NYLOCK NUT	18.8 S.S.
14	PACKING	PREMIUM CARBON
15	L-SHAPE SEAL	VITON
16	HARDENED INSERT RING	420 S.S.
17	HARDENED BACKUP PLATE	420 S.S.
18	AIR CYLINDER ASSEMBLY	N/A
19	LIMIT SWITCH BRACKETS	STAINLESS STEEL